

WINSTAT BF-X2ME



NEW

Desktop Type Ionizer

Compact Desktop Ionizer BF-X2ME
Light weight and long Stability performance



FEATURE

- With SSD HDC-AC technology it controlled Ion Balance below 5 volts without Feed Back system
- Keep long stability performance with less particle attach and emitter decrease onto the discharge emitter
- Easy Maintenance with detachable front cover
- Abnormal Power alarm and Fan alarm with LED lights and Signal output
- Keep the angle with lock system

Specifications

Model	BF-X2ME
Input Voltage	DC24V (AC100~240V AC adaptor)
Capacity	10VA
Output Voltage	$\pm 7,500V_{0-p}$
Ion Balance	Below $\pm 5V$ (Distance: 300mm)
Decay time	Less 1.5 seconds (Distance: 300mm, with Maximum air speed)
Air Flow	1.4 ~ 3.1m ³ /min
Air Speed	1.5 ~ 3.0m/sec (Distance: 300mm center)
Ozone level	Less 0.004ppm (Distance: 150mm)
Available Environment	0 ~ 40 °C / 15 ~ 85%RH (Without any condensation)
Filter	Pre-filter level
Signal Output	MOS FET Relay non voltage contact (NC Output) (High voltage abnormal or Fan abnormal: OFF.)
Dimensions	150 × 182 × 76mm (W × H × D)
Gross Weight	Approx. 1,000g (with Bracket)
Materials	Body: ABS, Emitter: Tungsten, Bracket: SECC, Front Louver cover: Conductive PC/ABS
Sound Level	60dB(A) (Distance: 1m)
Accessories	Manual, AC Adaptor, Conductive wide angle louver, Signal out cable
Optional part	Emitter unit, Filter (10pcs/pack)

Decay Performance

Decay Performance

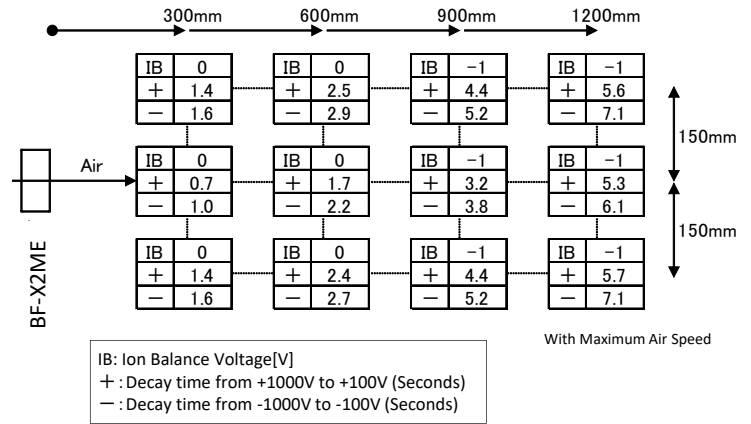

- *1): Plate size: 150mm x 150mm, Capacity: 20pF
- *2): Data with maximum air speed
- *3): This is reference data

Optional Part

● Emitter Unit: DNU-W85



● Filter (10pcs/pack): OBF-F2MA-1-10



OUTLOOK

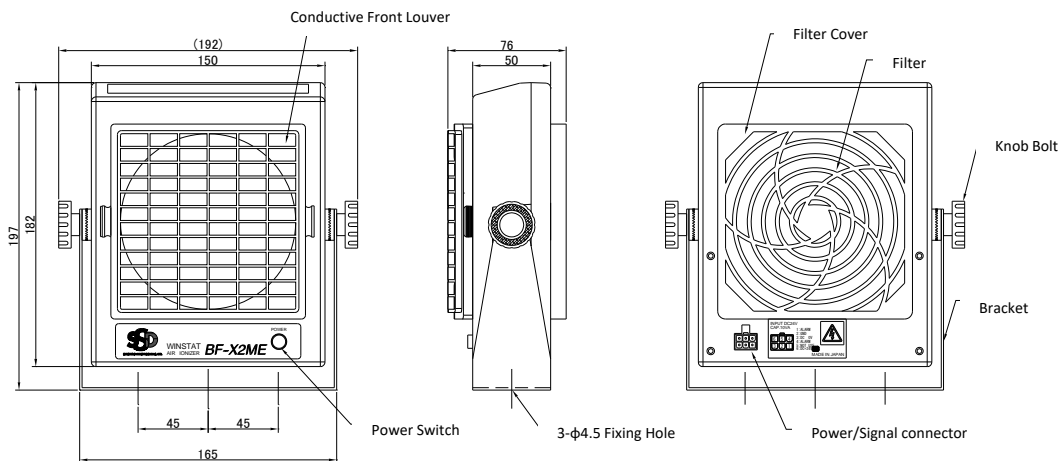

● 表示機能部

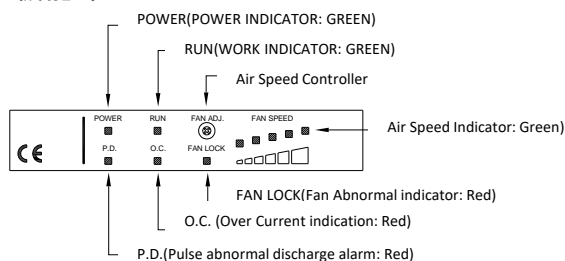

Real ESD Solutions & New Technology
SHISHIDO ELECTROSTATIC LTD.
 Overseas Department:
 3-3, 1-chome, Higashi-Yukigaya, Ota-ku,
 Tokyo. 145-0065 JAPAN